

*get started*

**INSTANT® VORTEX® PLUS  
DUAL AIR FRYER 8QT**

USER MANUAL

Instant

# Welcome

to your new Instant® Vortex® Plus!

This Instant Vortex Plus Dual Air Fryer with ClearCook™ can help you cook delicious meals with less oil and less hassle. We hope you fall in love with Instant air frying, and enjoy it in your kitchen for years to come!

Get started with your new Vortex Plus!



## **⚠️ WARNING**

Before using your new Vortex Plus, read all instructions, including the Safety Instructions and the Warranty. Failure to follow the safeguards and instructions may result in personal injury and/or property damage.

## CONTENTS

Important safeguards	2
What's in the box	7
Using your Vortex® Plus	8
Initial setup	10
Cooking	12
Smart Programs	16
Using both baskets	19
Cleaning	22
Troubleshooting	23
Error Codes	24
Replacement parts	25
Learn more	26
Warranty	27

# **IMPORTANT SAFEGUARDS**

## **⚠ WARNING**

Failure to follow safety instructions may result in personal injury and/or property damage and may void your warranty.

## READ ALL INSTRUCTIONS

Before using your new appliance, please read all instructions, including the Safety Information below. Keep this manual for reference.

### Placement

- **DO** place the appliance on a countertop only. Always operate the appliance on a stable, non-combustible, level surface.
- **DO** make sure all parts are dry and free of food debris before use.
- **DO** use extreme caution when moving the appliance. Always let the appliance cool to room temperature before handling or moving.
- **DO NOT** place the appliance on butcher block, other wood surfaces, Formica, laminate or other combustible surfaces.
- **DO NOT** place the appliance or power cord on or close to a gas or electric stovetop or oven. **NEVER** use the appliance on your stove.
- **DO NOT** use the appliance near water, an external heat source or flame.
- **DO NOT** use outdoors. Keep out of direct sunlight.
- **DO NOT** place on anything that may block the vents on the appliance.
- **DO NOT** move the appliance if it contains hot oil or other hot liquids.

### General Use

- **DO** use the appliances handles when opening the door/basket.
- **DO** use oven mitts when removing accessories and handling hot items.
- **DO** place hot accessories on a heat-resistant surface or cooking plate.
- **DO NOT** touch the appliance's hot surfaces, or any accessories during or immediately after cooking because they will be hot.

## **⚠ WARNING**

- **DO NOT** cover the basket, cooking tray or any part of the appliance with foil. This will cause overheating of the appliance, which may result in personal injury, fire, and/or property damage.
- **DO NOT** move the appliance while it is in use.
- **DO NOT** allow children or persons with reduced physical, sensory or mental capabilities to operate this appliance. Close supervision is necessary when any appliance is used by or near children and persons with reduced physical, sensory or mental capabilities. Children should not play with this appliance.
- **DO NOT** use the appliance for anything other than household use. It is not intended for commercial use.
- **DO NOT** leave the appliance unattended while in use.
- **DO NOT** use the appliance for more than 60 minutes in a 2-hour period. Exceptions are when using programs that cook at temperatures under 400° F / 204° C.

### **Air Frying Cautions**

When the air fryer is in operation, hot air is released through the air vents. Keep your hands and face away from the air vents and take extreme caution when removing hot accessories from the appliance.

**Failure to do so may result in personal injury and/or property damage.**

While cooking, the internal temperature of the appliance reaches several hundred degrees. To avoid personal injury, never place unprotected hands inside the appliance until it has cooled to room temperature.

- **DO** use caution when using cooking containers made of materials other than metal or glass. Failure to do so may result in personal injury, fire and/or property damage.
- **DO** use extreme caution when removing the basket/cooking tray or disposing of hot cooking residue.
- **DO NOT** use a ceramic-coated or stoneware pot for air frying.
- **DO NOT** cover or block the vents while the air fryer is operating. Doing so will prevent even cooking and may cause damage to the appliance. Leave at least 5 in / 13 cm of space around the air fryer when in use.
- **DO NOT** operate the appliance on or near combustible materials such as tablecloths and curtains.
- **DO NOT** use this appliance for deep frying foods.

## **⚠ WARNING**

- **DO NOT** pour oil into the cooking container. Using excess cooking oil could cause fire and result in personal injury and/or property damage.
- **DO NOT** use pressurized, aerosol oil sprays, since they contain chemicals that can damage the non-stick finish of the cooking tray. If needed, spray food lightly with oil with a high smoke point (such as refined avocado oil, safflower oil, refined sunflower oil, refined peanut oil, canola oil and refined coconut oil) from a non-aerosol, pump-style cooking spray before placing in the basket.
- **DO NOT** use this appliance for making popcorn.
- Should the unit emit black smoke during use, press **Cancel** and unplug the appliance immediately. Wait for smoking to stop before removing the lid, then clean thoroughly. For further information refer to 'Troubleshooting'.

### Overfill During Cooking

- **DO NOT** overfill the unit when air frying. Overfilling may cause food to contact the heating element, which may result in personal injury, fire, and/or property damage. Only place food in a single layer and do not stack food. For units with an air fry basket, do not fill more than 3/4 full. Best air frying results require air circulating through the food.
- **DO NOT** allow food to contact the heating element.

### Accessories

- **DO** use only accessories or attachments authorized by Instant Pot Brands. The use of parts, accessories or attachments not recommended by the manufacturer may cause a risk of electric shock or other personal injury, fire and/or property damage.
- **DO NOT** use the included accessories in a microwave, toaster oven, convection or conventional oven, on a ceramic, electric or gas cooktop, or with an outdoor grill.

### Care and Storage

- **DO** let the appliance cool to room temperature before cleaning or storage.
- **DO NOT** store any materials in the appliance when not in use.
- **DO NOT** place any combustible materials in the appliance, such as paper, cardboard, plastic, Styrofoam or wood.

## **⚠ WARNING**

- **DO NOT** clean the appliance with metal scouring pads or steel wool. Pieces can break off and touch the electrical parts, causing a risk of shock, burns or other personal injury.

### **Power Cord**

A short power-supply cord is used to reduce the risk resulting from grabbing, entanglement or tripping. **WARNING:** Hot spilled food can cause serious burns.

- **DO** keep appliance and cord away from children.
- **DO NOT** let the power cord hang over edge of tables or counters.
- **DO NOT** let the power cord touch hot surfaces or open flame, including the stovetop.
- **DO NOT** use below-counter power outlets.

This appliance has a 3-prong grounding plug. To reduce the risk of electric shock:

- **ONLY** plug the power cord into a grounded electrical outlet.
- **DO NOT** remove the grounding prong on the electrical plug.
- **DO NOT** use with extension cords, power converters or adapters, timer switches or separate remote-control systems.

### **Electrical Cautions**

The appliance contains electrical components that are an electrical shock hazard. **Failure to follow these instructions may result in electric shock and/or death.**

#### **To protect against electrical shock:**

- To disconnect, select **Cancel**, then remove plug from power source. Always unplug when not in use, as well as before adding or removing parts or accessories, and before cleaning. To unplug, grasp the plug and pull from the outlet. **NEVER** pull from the power cord.
- **DO** regularly inspect the appliance and power cord for any signs of damage or fraying.
- **DO NOT** operate the appliance if the power cord or plug is damaged, or after the appliance malfunctions or is dropped or damaged in any manner. For assistance, contact Consumer Care by email at **support@instantpot.com**.

## **⚠ WARNING**

- **DO NOT** attempt to dislodge food while the appliance is plugged in to an electrical outlet as this may lead to electric shock, burns or other personal injury, and/or property damage.
- **DO NOT** attempt to repair, replace or modify components of the appliance, as this may cause electric shock or other personal injury, fire and/or property damage, and will void the warranty. For assistance, contact Consumer Care by email at **support@instantpot.com**.
- **DO NOT** tamper with any of the safety mechanisms, as this may result in personal injury and/or property damage.
- **DO NOT** immerse power cord, plug or the appliance in water or other liquid.
- **DO NOT** clean the appliance by rinsing it under a faucet.
- **DO NOT** use the appliance in electrical systems other than 120 V ~ 60 Hz for North America.

## **SAVE THESE INSTRUCTIONS**

## **⚠ WARNING**

**Failure to follow safety instructions may result in personal injury and/or property damage and may void your warranty.**

# WHAT'S IN THE BOX

## Air Fryer

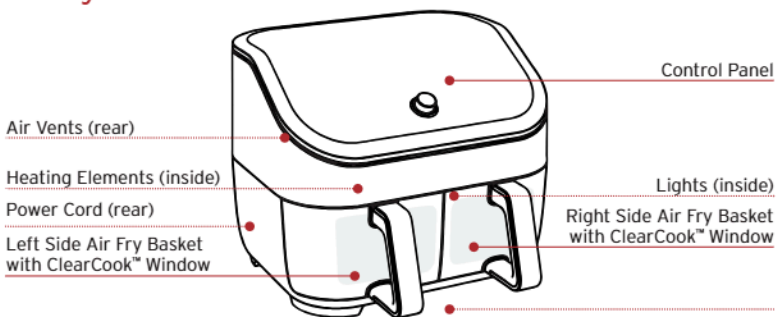

## Parts + accessories



*Illustrations are for reference only and may differ from the actual product.*

## Remember to recycle!

We designed this packaging with sustainability in mind. Please recycle everything that can be recycled where you live. Be sure to keep this manual for reference.

# USING YOUR VORTEX® PLUS

## Control panel

We've designed the control panel to be simple to use and easy to read.

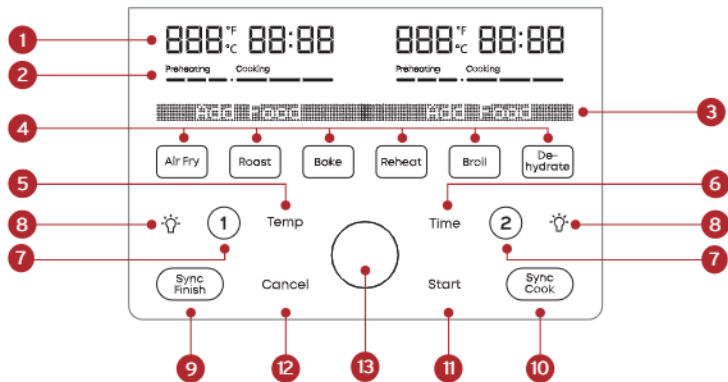

1. Left + Right Basket Status Display
  - Cooking temperature
  - Cooking time
2. Left + Right Basket Progress Bars
3. Left + Right Basket Message Bars
  - Messages
  - Error codes
4. Smart Programs
5. Temperature Control
  - Increase or decrease cooking temperature
6. Time Control
  - Increase or decrease cooking time
7. Left (1) + Right (2) Basket Selectors
8. Light indicators
9. SyncFinish
  - Set separate programs to end at the same time
10. SyncCook
  - Match right and left basket settings
11. Start
12. Cancel
13. Control Panel

## Turning the sound On/Off

You can set notification sounds to ON or OFF.

- When in Ready or cooking modes, press and hold **Time** and **Temp** for 5 seconds until the display shows **Sound On** or **Sound Off**.

*Error alerts cannot be turned off.*

## Choosing the temperature scale

You can display cooking temperature in either Fahrenheit or Celsius.

- When in Ready or Cooking modes, press and hold **Temp** for 5 seconds until the display shows °F or °C.

## Reset Smart Programs to original settings

### Reset individual Smart Programs

- Once you've selected the Smart Program, press and hold that Smart Program button for 3 seconds.

*The Smart Program's button blinks and the cooking time and temperature are restored to the factory default setting.*

### Reset all Smart Programs

- With the cooker in Ready mode, press and hold the **Control Dial** for 3 seconds until the cooker beeps.

*All Smart Program cooking times and temperatures are restored to the factory default setting.*

# INITIAL SETUP

## Unpack

1. Remove your new Instant Vortex® Plus from the box.
2. Remove all the packaging material from in and around the air fryer.
3. Make sure to remove all the accessories from inside the air fryer.
4. Don't remove the safety warning stickers or the rating label from the air fryer.

## Clean before use

1. Wipe the interior with a damp cloth. Use a clean, soft cloth to dry.
2. Wash the accessories with hot water and dish soap. Rinse with warm, clear water and use a soft cloth to dry.

## Placement

1. Place your air fryer on a stable, level, non-combustible surface, away from combustible material and external heat sources. Do not place your air fryer on top of another appliance, such as a stove.
2. Make sure to leave at least 5 in / 13 cm of space above and around all sides of the appliance to allow for sufficient air flow.

## Test run

Before using your new air fryer for the first time, perform a test run to ensure everything is working correctly.

### To perform a test run:

1. Follow the instructions for Cooking on page 12.
2. Insert the cooking basket, but do not add food.
3. Select basket 1.
4. The Air Fry program activates by default.
5. Change the cooking temperature to 400°F / 205°C.
6. Change the cooking time to 18 minutes.

7. Select basket 2.
8. The Air Fry program activates by default.
9. Change the cooking temperature to 400°F / 205°C.
10. Change the cooking time to 18 minutes.
11. Press **Start** and the air fryer starts the test run.
12. When the display shows **Add Food**, just wait 10 seconds for the program to resume (do not add any food).
13. When the display shows **Turn Food**, just wait 10 seconds for the program to resume.
14. After the cooking session is done, let the unit cool.

*Now you're ready to cook a meal in your Instant Vortex® Plus!*

## COOKING

The Instant Vortex® Plus uses rapid air circulation to crisp or cook food, giving your meals all the rich, crispy flavor of deep frying, with little to no oil.

### **⚠ WARNING**

#### **HOT SURFACES**

The air fryer will be hot during and after cooking. Always exercise extreme caution when removing food from the hot cooking chamber. Touching hot surfaces may result in personal injury, and/or property damage.

#### **MUST ALLOW AIR FLOW**

To prevent personal injury, and/or property damage, do not block air intake or air vents.

### **What to cook in**

The cooking basket and cooking tray are perforated to allow air to flow under and around your food, and should be used for most foods, like wings and cauliflower bites.

*You can place food right on the cooking tray, without using foil or other coverings.*

For the Baking program only, you can use a metal or glass baking dish to hold things like batter for cakes and dough for breads. Place the baking dish inside the cooking basket for baking.

## How to cook

These instructions explain how to cook using one basket at a time. See page 19 for information on using both baskets.

### Prep

Thaw, cut, season or batter your ingredients according to your recipe.

### Cook

1. For the Dehydrate and Reheat programs, place your food on the cooking tray inside the air fry basket, insert the basket into the air fryer and close the door.
2. For the Air Fry, Roast, Bake and Broil programs, insert the air fry basket with the cooking tray (without food) into the air fryer and close the door.

*You'll add food once the unit is preheated.*

3. Press **1** (to cook in left basket) or **2** (to cook in right basket).  
*The default program Air Fry button blinks and the display shows the default time and temperature.*
4. If you want to select a smart program other than Air Fry, press the button for the program you want to use.  
*The default time and temperature are displayed for that smart program.*
5. If you want to adjust the cooking time, press **Time** and use the **Control Dial** to increase or decrease it.
6. If you want to adjust the cooking temperature, press **Temp** and use the **Control Dial** to increase or decrease it.
7. Press **Start** to begin. The message bar shows the selected Smart Program and the progress bar shows **Preheating**.

## Add food

For the Air Fry, Roast, Bake and Broil programs:

1. When the unit is preheated, the message bar shows **Add Food**.
2. Remove the basket and carefully add your food into the basket.
3. Reinsert the basket into the cooker. The cooking countdown timer starts and the progress bar shows **Cooking**.

## Turn

For the Air Fry and Roast programs:

1. Part way through the cooking cycle the message bar shows **Turn Food**.

*If you do not remove the basket after **Turn Food** displays, cooking will proceed after 10 seconds.*

2. Remove the basket and carefully turn, flip, or rotate your food.
3. Reinsert the basket into the air fryer. Cooking continues.

## Finish

1. When the smart program completes, the air fryer beeps and the message bar shows **End**.

*The air fryer beeps after*

## Changing cooking time during cooking

You can change the cooking time after you've started a smart program:

1. Press **1** or **2** to select the basket you want to change.
2. Press **Time** and use the Control Dial to increase or decrease it.
3. Then press the Control Dial to confirm the change.
4. Press **Start** to continue cooking.

*If you don't press Start, cooking continues using the former settings.*

## Changing cooking temperature during cooking

You can change the cooking time after you've started a smart program:

1. Press **1** or **2** to select the basket you want to change.
2. Press **Temperature** and use the Control Dial to increase or decrease it.
3. Then press the Control Dial to confirm the change.
4. Press **Start** to continue cooking.

*If you don't press Start, cooking continues using the former settings.*

## Cancel cooking during cooking

You can cancel cooking at any time after you've started a smart program:

1. Press **1** or **2** to select the basket you want to cancel.
2. Press **Cancel**.

*If you press **Cancel** without selecting a basket, both baskets will be canceled.*

## SMART PROGRAMS

### Air Fry

You can air fry foods like fries, cauliflower bites, wings, nuggets and more.

Setting	Default	Minimum	Maximum
Temperature	385°F / 196°C	180°F / 82°C	400°F / 205°C
Cooking Time	15 minutes (00:15)	1 minute (00:01)	1 hour (01:00)

#### To air fry

- Follow the basic instructions for Cooking.
- Select “Air Fry” as the Smart Program.

### Roast

You can roast foods like beef, lamb, pork, poultry, vegetables and scalloped potatoes, for a deliciously tender inside and browned outside.

Setting	Default	Minimum	Maximum
Temperature	400°F / 205°C	180°F / 82°C	400°F / 205°C
Cooking Time	18 minutes (00:18)	1 minute (00:01)	1 hour (01:00)

#### To roast

- Follow the basic instructions for Cooking.
- Select “Roast” as the Smart Program.

### Bake

You can bake foods like breads, cakes, chicken breasts or potatoes, using your air fryer instead of heating up your regular oven.

Setting	Default	Minimum	Maximum
Temperature	350°F / 176°C	180°F / 82°C	400°F / 205°C
Cooking Time	20 minutes (00:20)	1 minute (00:01)	1 hour (01:00)

## To bake

- Follow the basic instructions for Cooking.
- Select “Bake” as the Smart Program.
- There is no need to turn the food partway through cooking.

*Leave approximately 1 in / 2.5 cm of space around all sides of the baking dish to allow heat to circulate evenly.*

## What to cook in

- For soft foods (like bread dough), liquid-based foods (like cake batter) and foods that may drip during cooking (like chicken breasts), use a metal or glass baking dish. Place the baking dish inside the air fryer basket for baking. Leave approximately 1”/ 2.5 cm of space around all sides of the baking dish to allow heat to circulate evenly.
- For solid foods (like potatoes), use the air fryer basket or cooking tray.

*You can place food right on the cooking tray, without using foil or other coverings.*

## Broil

Broiling cooks using direct top-down heating, perfect for melting cheese on French onion soup, and nachos.

Setting	Default	Minimum	Maximum
Temperature	400°F / 205°C	400°F / 205°C	450°F / 232°C
Cooking Time	6 minutes (00:06)	1 minute (00:01)	30 minutes (00:30)

## To broil

- Follow the basic instructions for Cooking.
- Select “Broil” as the Smart Program.
- There is no need to turn the food partway through cooking.

## Dehydrate

Dehydrating uses low heat over a long period of time to safely dry out food items, like dried fruit, jerky and dried veggies.

Setting	Default	Minimum	Maximum
Temperature	130°F / 54°C	95°F / 35°C	175°F / 79°C
Cooking Time	8 hours (08:00)	1 hour (01:00)	72 hours (72:00)

### To dehydrate

- Follow the basic instructions for Cooking.
- Select “Dehydrate” as the Smart Program.
- There is no need to turn the food partway through cooking.

## Reheat

Bring the crisp and crunch back to leftovers, in just a few minutes.

Setting	Default	Minimum	Maximum
Temperature	280°F / 138°C	120°F / 49°C	360°F / 182°C
Cooking Time	10 minutes (00:10)	1 minute (00:01)	1 hour (01:00)

### To reheat

- Follow the basic instructions for Cooking.
- Select “Reheat” as the Smart Program.

*Once this Smart Cooking function starts, the display will show the target temperature and cooking time immediately, there's no preheating time.*

## USING BOTH BASKETS

The Instant Vortex® Plus Dual Air Fryer let you use cook in both baskets at the same time, with 3 options:

### Cook in both baskets

Cook in both baskets at the same time, using different programs and settings.

### SyncCook

Cook in both baskets at the same time, using the same program and settings for both.

### SyncFinish

Cook in both baskets at the same time, using different programs and settings for each, but finish cooking at the same time.

## How to cook in both baskets

1. Follow the instructions for Cooking on page 12 and any specific instructions for the smart program you want to use.
2. Set up your first program in the left basket (select 1), including any changes to time and temperature settings if you want.
3. Press **2** to start setting up a second smart program in the right basket including any changes to time and temperature settings if you want.
4. Then press **Start** and continue following the instructions for Cooking.

*You can also start the first program in the right basket (select 2) and then set up the left basket (select 1).*

## How to SyncCook™

1. Follow the instructions for Cooking on page 12 and any specific instructions for the smart program you want to use.
2. After you've set up your first program (in either basket) but before pressing Start, press **SyncCook**.

*The SyncCook icon displays.* 

3. Then press **Start** and continue following the instructions for Cooking.

## About SyncCook

- You can change the cooking time and temperature settings for both baskets (SyncCook will remain ON) by adjusting the cooking time or temperature.
- You can change the cooking time and temperature settings for either basket (SyncCook will turn OFF) by pressing 1 or 2 to select a basket to change and then adjusting the cooking time or temperature.
- If you remove one basket during cooking, the other basket will keep cooking. The display will still show the SyncCook icon, but the cooking times will be different in the two baskets.

## Ending SyncCook

You can end SyncCook at any time to make changes to one or both cooking programs.

1. Press 1 or 2 to select the basket you'd like to make changes to.  
*SyncCook stops and the icon no longer displays.*
2. Adjust the cooking time or temperature settings and press the **Control Dial** to confirm the changes.
3. Press **Start** to continue cooking, with each basket cooking with its own program and settings.

## How to SyncFinish™

1. Follow the instructions for Cooking on page 12 and any specific instructions for the smart program you want to use.
2. Set up your first program in either basket (select 1 or 2) including any changes to time and temperature settings if you want.
3. Press 1 or 2 to select the other basket and start setting up a smart program in that basket, including any changes to time and temperature settings if you want.
4. Press **SyncFinish**.

The SyncFinish icon displays. 

5. Press **Start** and continue following the instructions for Cooking.

*The air fryer will calculate the cooking times and start cooking each basket at the appropriate time so they finish together.*

#### About SyncFinish

- *If you need to remove one of the baskets during cooking, cooking in the other basket will pause to keep the two in sync.*

#### Ending SyncFinish

You can end SyncFinish if you need to make changes to the cooking programs by pressing **Cancel**. After that, reselect a program and settings for each basket.

## CLEANING

Clean your Instant Vortex® Plus after each use. Always let all parts cool to room temperature before cleaning. Before use or storing, make sure all surfaces are dry.

### **⚠ WARNING**

To prevent electric shock, unplug before cleaning.

**DO NOT** immerse power cord, plug or the appliance in water or other liquid, which may result in electric shock.

Part	Cleaning instructions
Cooking trays	<ul style="list-style-type: none"><li>• Dishwasher safe* or hand wash with a damp cloth and mild dish soap.</li><li>• The cooking trays have a non-stick coating. Avoid using metal utensils when cleaning.</li><li>• Avoid using harsh cleaners.</li></ul>
Removable air frying basket	<ul style="list-style-type: none"><li>• Dishwasher safe* or hand wash with a damp cloth and mild dish soap.</li><li>• This basket has a non-stick coating. Avoid using metal utensils when cleaning.</li><li>• Avoid using harsh cleaners</li></ul>
Cooking chamber	<ul style="list-style-type: none"><li>• Clean with a damp cloth and mild dish soap.</li><li>• Always check the heating coil and cooking chamber walls for oil spatter and food debris, and clean as needed.</li><li>• Ensure the heating coil is dry before turning on the air fryer.</li><li>• To remove baked-on grease and food residue from the cooking chamber, spray with a mixture of baking soda and vinegar and wipe clean with damp cloth. For stubborn stains, allow the mixture to sit on the affected area for several minutes before scrubbing clean.</li></ul>
Power cord	<ul style="list-style-type: none"><li>• Clean with a soft, damp cloth or sponge. Wipe dry.</li></ul>

*\*Some discoloration may occur after washing in a dishwasher, but this will not affect the cooker's safety or performance.*

## TROUBLESHOOTING

Problem	Cause	Solution
Air fryer will not turn on	The appliance is not properly plugged in.	Make sure the power cord is plugged into the outlet firmly.
	Outlet is not powered.	Plug another appliance into the same outlet to test the circuit.
	The basket is not fully inserted into the air fryer.	Make sure the basket is fully inserted.
Black smoke is coming from the air fryer	Using an oil with a low smoke point.	Cancel the Smart Program, unplug the cooker and allow it to cool to room temperature. Choose a neutral oil with a high smoke point, such as Canola, Avocado, Soybean, Safflower, or Rice Bran.
	Food residue on the heating coil, in the cooking chamber or on the accessories.	Cancel the Smart Program, unplug the cooker and allow it to cool to room temperature. Remove all accessories from the cooking chamber and clean the cooking chamber and all accessories thoroughly.
	Appliance malfunction.	Contact Consumer Care.
White smoke is coming from the air fryer	Cooking foods with a high fat content, such as bacon, sausage, and hamburger	Avoid air frying foods with a high fat content. Check the cooking chamber for excess oil and/or fat and carefully remove as needed before air frying.
	Water is vaporizing, producing thick steam.	Pat dry moist food ingredients before air frying. Do not add water or other liquid to the cooking chamber when air frying.
	Seasoning on food has blown into element	Be mindful when seasoning food. Spray vegetables and meats with oil before seasoning to help the seasoning stick.





## ERROR CODES

If the control panel displays an error code from this list, there is an issue with the Vortex® Plus. Here are the actions you should take to fix the problem.

Problem	Cause	Solution
E1	Open circuit.	Contact Consumer Care.
E2	Temperature sensor short circuit.	Contact Consumer Care.

## REPLACEMENT PARTS

We offer genuine replacement parts for your Instant Vortex Plus, if you need them. Visit [www.instantpot.com](http://www.instantpot.com) to order.

	Part	Part number
	Left Side Air Fry Basket	310-0178-01
	Right Side Air Fry Basket	310-0179-01
	Left Side Cooking Tray	210-0169-01
	Right Side Cooking Tray	210-0170-01
	User Manual	399-1279-03US

## LEARN MORE

There's a whole world of Instant® cooking information and help just waiting for you. Here are some of the most helpful resources.

### Register your product

[Instantpot.com/register](https://Instantpot.com/register)

### Contact Consumer Care

In the Instant Connect™ App  
[Instantpot.com/customer-care-center](https://Instantpot.com/customer-care-center)  
[support@instantpot.com](mailto:support@instantpot.com)

### Download the Instant Connect™ App

Discover guided cooking and recipes  
Available at iOS and Android app stores

### Cooking charts and more recipes

[Instantpot.com](https://Instantpot.com)

### How-to videos, tips and more

[Instantpot.com](https://Instantpot.com)

### Replacement parts and accessories

[Instantpot.com](https://Instantpot.com)

### Join the community



## Product specifications

Model	Volume		Wattage	Power
DAF8132BK [Black finish]	<b>Total</b> 8 Quarts 7.5 Litre	<b>Each basket</b> 4 Quarts 3.7 Litres	1700 W	120 V/ 60 Hz
DAF8132SS [Stainless Steel finish]	<b>Total</b> 8 Quarts 7.5 Litres	<b>Each basket</b> 4 Quarts 3.7 Litres	1700 W	120V/ 60Hz

# WARRANTY

## One (1) Year Limited Warranty

This One (1) Year Limited Warranty applies to purchases made from authorized retailers of Instant Pot Brands by the original appliance owner and is not transferable. Proof of original purchase date and, if requested by Instant Pot Brands, return of your appliance, is required to obtain service under this Limited Warranty. Provided the appliance was used in accordance with the use & care instructions, Instant Pot Brands will, in its sole and exclusive discretion, either: (i) repair defects in materials or workmanship; or (ii) replace the appliance. In the event that your appliance is replaced, the Limited Warranty on the replacement appliance will expire twelve (12) months from the date of receipt. Failure to register your product will not reduce your warranty rights. The liability of Instant Pot Brands, if any, for any allegedly defective appliance or part will not exceed the purchase price of a comparable replacement appliance.

## What is not covered by this warranty?

- Products purchased, used, or operated outside of the United States and Canada.
- Products that have been modified or attempted to be modified.
- Damage resulting from accident, alteration, misuse, abuse, neglect, unreasonable use, use contrary to the operating instructions, normal wear and tear, commercial use, improper assembly, disassembly, failure to provide reasonable and necessary maintenance, fire, flood, acts of God, or repair by anyone unless directed by an Instant Pot Brands representative.
- Use of unauthorized parts and accessories.
- Incidental and consequential damages.
- The cost of repair or replacement under these excluded circumstances.

EXCEPT AS EXPRESSLY PROVIDED HEREIN AND TO THE EXTENT PERMITTED BY APPLICABLE LAW, INSTANT POT BRANDS MAKES NO WARRANTIES, CONDITIONS OR REPRESENTATIONS, EXPRESS OR IMPLIED, BY STATUTE, USAGE, CUSTOM OF TRADE OR OTHERWISE WITH RESPECT TO THE APPLIANCES OR PARTS COVERED BY THIS WARRANTY, INCLUDING BUT NOT LIMITED TO, WARRANTIES, CONDITIONS, OR REPRESENTATIONS OF WORKMANSHIP, MERCHANTABILITY, MERCHANTABILITY, FITNESS FOR A PARTICULAR PURPOSE OR DURABILITY.

Some states or provinces do not allow for: (1) the exclusion of implied warranties of merchantability or fitness; (2) limitations on how long an implied warranty lasts; and/or (3) the exclusion or limitation of incidental or consequential damages; so these limitations may not apply to you. In these states and provinces, you have only the implied warranties that are expressly required to be provided in accordance with applicable law. The limitations of warranties, liability, and remedies apply to the maximum extent permitted by law. This limited warranty gives you specific legal rights, and you may also have other rights which vary from state to state or province to province.

## Product Registration

Please visit [www.instantpot.com/register](http://www.instantpot.com/register) to register your new Instant Pot Brands appliance. Failure to register your product will not diminish your warranty rights. You will be asked to provide the store name, date of purchase, model number (found on the back of your appliance) and serial number (found on the bottom of your appliance) along with your name and email address. The registration will enable us to keep you up to date with product developments and recipes, and contact you in the unlikely event of a product safety notification. By registering, you acknowledge that you have read and understand the instructions for use, and warnings set forth in the accompanying instructions.

## Warranty Service

To obtain warranty service, please contact our Consumer Care Department by email to [support@instantpot.com](mailto:support@instantpot.com). You can also create a support ticket online at [www.instantpot.com](http://www.instantpot.com). If we are unable to resolve the problem, you may be asked to send your appliance to the Service Department for quality inspection. Instant Pot Brands is not responsible for shipping costs related to warranty service. When returning your appliance, please include your name, mailing address, email address, phone number, and proof of the original purchase date as well as a description of the problem you are encountering with the appliance.



**⚠ WARNING**

**DO NOT** place this appliance on or close to a gas or electric burner, or inside an oven. Always operate this appliance on a stable, non-combustible, level surface, such as a kitchen countertop.



In Canada, distributed by  
Instant Pot Brands  
199 Bay Street, Suite 4000  
Toronto, ON M5L 1A9

In U.S., distributed by  
Instant Pot Brands  
3025 Highland Parkway, Suite 700  
Downers Grove, IL 60515 U.S.

**instantpot.com**

© 2024 Instant Pot Brands  
140-3090-01, 140-3090-02, 140-3118-01,  
140-3118-02

Art release date  
04/29/2024

INSTANT and VORTEX  
are registered trademarks  
of Instant Pot Brands